



- 1
- 2
- 3
- 4
- 5
- 6
- 7
- 8
- 9
- 10
- 11
- 12
- 13
- 14
- 15

BASE

Glass-fibre reinforced polyamide based (PA) special conductive technopolymer, black colour, matte finish.

Surface resistivity = $10^3 \Omega$ (ASTM D257 measuring method).

Volume resistivity = $10^3 \Omega\text{cm}$ (ASTM D257 measuring method).

ARTICULATED STEM

Threaded zinc-plated steel with regulation hexagon.

STANDARD EXECUTIONS

- **LV.A-ESD-C**: without no-slip disk.

- **LV.A-AS-ESD-C**: with NBR conductive rubber, hardness 70 Shore A, supplied assembled.

Surface resistivity = $10^3 \Omega$ (ASTM D991 measuring method).

Volume resistivity = $10^3 \Omega\text{cm}$ (ASTM D991 measuring method).

FEATURES AND APPLICATIONS

The special conductive technopolymer (ESD-C Electrostatic Discharge Conductive) prevents the accumulation of electrostatic charge.

The particular assembling system of the no-slip disk to the base assures a perfect anchoring, preventing separation even in case of impact during transport or of adhesion (sticking) to the floor (see No-slip disks on page 979).

The bases are suitable for "ESD PROTECTED AREA" (EPA) where components, which are susceptible to electrostatic discharges, are handled. The (ESD-C) indelibly printed mark on the surface of the levelling elements bases identifies the particular conductive features of the material according to EN 100015/1 and IEC 61340-5-1.

ORDER INFORMATION

The levelling elements are supplied unassembled to make carriage and storage easier. The components (base and stem) are supplied in separate packing; less volume taken and better protection from scratches and dirt.

To order bases and stems separately, see:

- table of possible combinations Bases/Stems (see page 984)
- the codes of the Bases (see page 838)
- the codes of the Stems (see page 986).

ACCESSORIES ON REQUEST

Zinc-plated steel nut (see Nuts NT. on page 979).



ELESA Original design

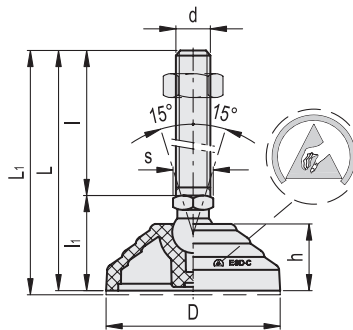

Conversion Table 1 mm = 0.039 inch	
D	
mm	inch
60	2.36
70	2.76
80	3.15
100	3.94
125	4.92

METRIC

LV.A-ESD-C

LV.A-AS-ESD-C

Code	Description	Code	Description	D	d	L	Li#	l	li	h	s	Articulation \emptyset	Max. limit static load* [N]	\triangle	\triangle	#
303121-ESD	LV.A-60-14-M8x43-ESD-C	307121-ESD	LV.A-60-14-AS-M8x43-ESD-C	60	M8	76	79	43	33	24	14	14	14000	62	81	
303125-ESD	LV.A-60-14-M8x68-ESD-C	307125-ESD	LV.A-60-14-AS-M8x68-ESD-C	60	M8	101	104	68	33	24	14	14	14000	74	93	
303221-ESD	LV.A-60-14-M10x43-ESD-C	307221-ESD	LV.A-60-14-AS-M10x43-ESD-C	60	M10	76	79	43	33	24	14	14	14000	71	90	
303225-ESD	LV.A-60-14-M10x68-ESD-C	307225-ESD	LV.A-60-14-AS-M10x68-ESD-C	60	M10	101	104	68	33	24	14	14	14000	83	102	
303231-ESD	LV.A-60-14-M10x98-ESD-C	307231-ESD	LV.A-60-14-AS-M10x98-ESD-C	60	M10	131	134	98	33	24	14	14	14000	97	116	
303321-ESD	LV.A-60-14-M12x43-ESD-C	307321-ESD	LV.A-60-14-AS-M12x43-ESD-C	60	M12	76	79	43	33	24	14	14	14000	81	100	
303325-ESD	LV.A-60-14-M12x68-ESD-C	307325-ESD	LV.A-60-14-AS-M12x68-ESD-C	60	M12	101	104	68	33	24	14	14	14000	98	117	
303331-ESD	LV.A-60-14-M12x98-ESD-C	307331-ESD	LV.A-60-14-AS-M12x98-ESD-C	60	M12	131	134	98	33	24	14	14	14000	119	138	
303421-ESD	LV.A-60-14-M14x68-ESD-C	307421-ESD	LV.A-60-14-AS-M14x68-ESD-C	60	M14	101	104	68	33	24	14	14	14000	120	139	
303431-ESD	LV.A-60-14-M14x98-ESD-C	307431-ESD	LV.A-60-14-AS-M14x98-ESD-C	60	M14	131	134	98	33	24	14	14	14000	141	160	
303441-ESD	LV.A-60-14-M14x148-ESD-C	307441-ESD	LV.A-60-14-AS-M14x148-ESD-C	60	M14	181	184	148	33	24	14	14	14000	224	243	
303521-ESD	LV.A-60-14-M16x68-ESD-C	307521-ESD	LV.A-60-14-AS-M16x68-ESD-C	60	M16	101	104	68	33	24	16	14	14000	142	161	
303525-ESD	LV.A-60-14-M16x108-ESD-C	307525-ESD	LV.A-60-14-AS-M16x108-ESD-C	60	M16	141	144	108	33	24	16	14	14000	194	213	
303541-ESD	LV.A-60-14-M16x148-ESD-C	307541-ESD	LV.A-60-14-AS-M16x148-ESD-C	60	M16	181	184	148	33	24	16	14	14000	246	265	
303561-ESD	LV.A-60-14-M16x168-ESD-C	307561-ESD	LV.A-60-14-AS-M16x168-ESD-C	60	M16	201	204	168	33	24	16	14	14000	272	291	

* The max static load is the value above which the load applied to the element may cause some plastic material breakage, in particular conditions of use. Obviously, a factor that takes into consideration the importance and the safety level of the specific application must be applied to this value.

Data with no-slip disk mounted.



LVA-ESD-C

LVA-AS-ESD-C

METRIC

Code	Description	Code	Description	D	d	L	L#	l	l1	h	s	Articulation ∅	Max. limit static load* [N]	⚖️	⚖️ #
303621-ESD	LVA-60-24-M16x58-ESD-C	307621-ESD	LVA-60-24-AS-M16x58-ESD-C	60	M16	101	104	58	43	24	24	24	18000	205	224
303625-ESD	LVA-60-24-M16x98-ESD-C	307625-ESD	LVA-60-24-AS-M16x98-ESD-C	60	M16	141	144	98	43	24	24	24	18000	256	275
303641-ESD	LVA-60-24-M16x138-ESD-C	307641-ESD	LVA-60-24-AS-M16x138-ESD-C	60	M16	181	184	138	43	24	24	24	18000	306	325
303661-ESD	LVA-60-24-M16x158-ESD-C	307661-ESD	LVA-60-24-AS-M16x158-ESD-C	60	M16	201	204	158	43	24	24	24	18000	333	352
303725-ESD	LVA-60-24-M20x98-ESD-C	307725-ESD	LVA-60-24-AS-M20x98-ESD-C	60	M20	141	144	98	43	24	24	24	18000	326	345
303741-ESD	LVA-60-24-M20x138-ESD-C	307741-ESD	LVA-60-24-AS-M20x138-ESD-C	60	M20	181	184	138	43	24	24	24	18000	405	424
303761-ESD	LVA-60-24-M20x158-ESD-C	307761-ESD	LVA-60-24-AS-M20x158-ESD-C	60	M20	201	204	158	43	24	24	24	18000	444	463
303781-ESD	LVA-60-24-M20x198-ESD-C	307781-ESD	LVA-60-24-AS-M20x198-ESD-C	60	M20	241	244	198	43	24	24	24	18000	527	546
303825-ESD	LVA-60-24-M24x98-ESD-C	307825-ESD	LVA-60-24-AS-M24x98-ESD-C	60	M24	141	144	98	43	24	24	24	18000	424	443
303861-ESD	LVA-60-24-M24x158-ESD-C	307861-ESD	LVA-60-24-AS-M24x158-ESD-C	60	M24	201	204	158	43	24	24	24	18000	596	615
303881-ESD	LVA-60-24-M24x198-ESD-C	307881-ESD	LVA-60-24-AS-M24x198-ESD-C	60	M24	241	244	198	43	24	24	24	18000	714	733
304005-ESD	LVA-70-14-M8x43-ESD-C	308005-ESD	LVA-70-14-AS-M8x43-ESD-C	70	M8	71	74	43	28	19	14	14	14000	60	80
304011-ESD	LVA-70-14-M8x68-ESD-C	308011-ESD	LVA-70-14-AS-M8x68-ESD-C	70	M8	96	99	68	28	19	14	14	14000	72	92
304021-ESD	LVA-70-14-M10x43-ESD-C	308021-ESD	LVA-70-14-AS-M10x43-ESD-C	70	M10	71	74	43	28	19	14	14	14000	69	89
304025-ESD	LVA-70-14-M10x68-ESD-C	308025-ESD	LVA-70-14-AS-M10x68-ESD-C	70	M10	96	99	68	28	19	14	14	14000	81	101
304031-ESD	LVA-70-14-M10x98-ESD-C	308031-ESD	LVA-70-14-AS-M10x98-ESD-C	70	M10	126	129	98	28	19	14	14	14000	95	115
304061-ESD	LVA-70-14-M12x43-ESD-C	308061-ESD	LVA-70-14-AS-M12x43-ESD-C	70	M12	71	74	43	28	19	14	14	14000	79	99
304065-ESD	LVA-70-14-M12x68-ESD-C	308065-ESD	LVA-70-14-AS-M12x68-ESD-C	70	M12	96	99	68	28	19	14	14	14000	96	116
304071-ESD	LVA-70-14-M12x98-ESD-C	308071-ESD	LVA-70-14-AS-M12x98-ESD-C	70	M12	126	129	98	28	19	14	14	14000	117	137
304075-ESD	LVA-70-14-M14x68-ESD-C	308075-ESD	LVA-70-14-AS-M14x68-ESD-C	70	M14	96	99	68	28	19	14	14	14000	118	138
304081-ESD	LVA-70-14-M14x98-ESD-C	308081-ESD	LVA-70-14-AS-M14x98-ESD-C	70	M14	126	129	98	28	19	14	14	14000	139	159
304085-ESD	LVA-70-14-M14x148-ESD-C	308085-ESD	LVA-70-14-AS-M14x148-ESD-C	70	M14	176	179	148	28	19	14	14	14000	222	242
304101-ESD	LVA-70-14-M16x68-ESD-C	308101-ESD	LVA-70-14-AS-M16x68-ESD-C	70	M16	96	99	68	28	19	16	14	14000	140	160
304105-ESD	LVA-70-14-M16x108-ESD-C	308105-ESD	LVA-70-14-AS-M16x108-ESD-C	70	M16	136	139	108	28	19	16	14	14000	192	212
304111-ESD	LVA-70-14-M16x148-ESD-C	308111-ESD	LVA-70-14-AS-M16x148-ESD-C	70	M16	176	179	148	28	19	16	14	14000	244	264
304115-ESD	LVA-70-14-M16x168-ESD-C	308115-ESD	LVA-70-14-AS-M16x168-ESD-C	70	M16	196	199	168	28	19	16	14	14000	270	290
304121-ESD	LVA-80-14-M8x43-ESD-C	308121-ESD	LVA-80-14-AS-M8x43-ESD-C	80	M8	76	79	43	33	24	14	14	16000	83	109
304125-ESD	LVA-80-14-M8x68-ESD-C	308125-ESD	LVA-80-14-AS-M8x68-ESD-C	80	M8	101	104	68	33	24	14	14	16000	95	121
304221-ESD	LVA-80-14-M10x43-ESD-C	308221-ESD	LVA-80-14-AS-M10x43-ESD-C	80	M10	76	79	43	33	24	14	14	16000	92	118
304225-ESD	LVA-80-14-M10x68-ESD-C	308225-ESD	LVA-80-14-AS-M10x68-ESD-C	80	M10	101	104	68	33	24	14	14	16000	104	130
304231-ESD	LVA-80-14-M10x98-ESD-C	308231-ESD	LVA-80-14-AS-M10x98-ESD-C	80	M10	131	134	98	33	24	14	14	16000	118	144
304321-ESD	LVA-80-14-M12x43-ESD-C	308321-ESD	LVA-80-14-AS-M12x43-ESD-C	80	M12	76	79	43	33	24	14	14	16000	102	128
304325-ESD	LVA-80-14-M12x68-ESD-C	308325-ESD	LVA-80-14-AS-M12x68-ESD-C	80	M12	101	104	68	33	24	14	14	16000	119	145
304331-ESD	LVA-80-14-M12x98-ESD-C	308331-ESD	LVA-80-14-AS-M12x98-ESD-C	80	M12	131	134	98	33	24	14	14	16000	140	166
304421-ESD	LVA-80-14-M14x68-ESD-C	308421-ESD	LVA-80-14-AS-M14x68-ESD-C	80	M14	101	104	68	33	24	14	14	16000	141	167
304431-ESD	LVA-80-14-M14x98-ESD-C	308431-ESD	LVA-80-14-AS-M14x98-ESD-C	80	M14	131	134	98	33	24	14	14	16000	162	188
304441-ESD	LVA-80-14-M14x148-ESD-C	308441-ESD	LVA-80-14-AS-M14x148-ESD-C	80	M14	181	184	148	33	24	14	14	16000	245	271
304521-ESD	LVA-80-14-M16x68-ESD-C	308521-ESD	LVA-80-14-AS-M16x68-ESD-C	80	M16	101	104	68	33	24	16	14	16000	163	189
304525-ESD	LVA-80-14-M16x108-ESD-C	308525-ESD	LVA-80-14-AS-M16x108-ESD-C	80	M16	141	144	108	33	24	16	14	16000	215	241
304541-ESD	LVA-80-14-M16x148-ESD-C	308541-ESD	LVA-80-14-AS-M16x148-ESD-C	80	M16	181	184	148	33	24	16	14	16000	267	293
304561-ESD	LVA-80-14-M16x168-ESD-C	308561-ESD	LVA-80-14-AS-M16x168-ESD-C	80	M16	201	204	168	33	24	16	14	16000	293	319
304621-ESD	LVA-80-24-M16x58-ESD-C	308621-ESD	LVA-80-24-AS-M16x58-ESD-C	80	M16	101	104	58	43	24	24	24	18000	225	251
304625-ESD	LVA-80-24-M16x98-ESD-C	308625-ESD	LVA-80-24-AS-M16x98-ESD-C	80	M16	141	144	98	43	24	24	24	18000	276	302
304641-ESD	LVA-80-24-M16x138-ESD-C	308641-ESD	LVA-80-24-AS-M16x138-ESD-C	80	M16	181	184	138	43	24	24	24	18000	326	352
304661-ESD	LVA-80-24-M16x158-ESD-C	308661-ESD	LVA-80-24-AS-M16x158-ESD-C	80	M16	201	204	158	43	24	24	24	18000	353	379
304725-ESD	LVA-80-24-M20x98-ESD-C	308725-ESD	LVA-80-24-AS-M20x98-ESD-C	80	M20	141	144	98	43	24	24	24	18000	346	372
304741-ESD	LVA-80-24-M20x138-ESD-C	308741-ESD	LVA-80-24-AS-M20x138-ESD-C	80	M20	181	184	138	43	24	24	24	18000	425	451
304761-ESD	LVA-80-24-M20x158-ESD-C	308761-ESD	LVA-80-24-AS-M20x158-ESD-C	80	M20	201	204	158	43	24	24	24	18000	464	490
304781-ESD	LVA-80-24-M20x198-ESD-C	308781-ESD	LVA-80-24-AS-M20x198-ESD-C	80	M20	241	244	198	43	24	24	24	18000	547	573
304825-ESD	LVA-80-24-M24x98-ESD-C	308825-ESD	LVA-80-24-AS-M24x98-ESD-C	80	M24	141	144	98	43	24	24	24	18000	444	470
304861-ESD	LVA-80-24-M24x158-ESD-C	308861-ESD	LVA-80-24-AS-M24x158-ESD-C	80	M24	201	204	158	43	24	24	24	18000	616	642
304881-ESD	LVA-80-24-M24x198-ESD-C	308881-ESD	LVA-80-24-AS-M24x198-ESD-C	80	M24	241	244	198	43	24	24	24	18000	734	760

* The max static load is the value above which the load applied to the element may cause some plastic material breakage, in particular conditions of use. Obviously, a factor that takes into consideration the importance and the safety level of the specific application must be applied to this value.

Data with no-slip disk mounted.



Levelling elements and supports

- 1
- 2
- 3
- 4
- 5
- 6
- 7
- 8
- 9
- 10
- 11
- 12
- 13
- 14
- 15
- RH
-

Conversion Table
1 mm = 0.039 inch

mm	inch
60	2.36
70	2.76
80	3.15
100	3.94
125	4.92

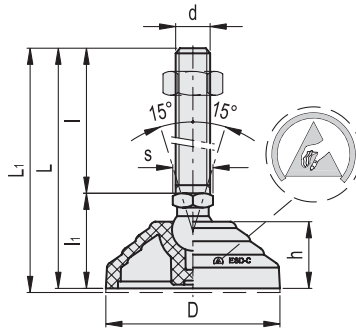

METRIC

LVA-ESD-C

LVA-AS-ESD-C

Code	Description	Code	Description	D	d	L	L1#	l	l1	h	s	Articulation ∅	Max. limit static load* [N]	△	△	#
305451-ESD	LVA-100-14-M8x43-ESD-C	309451-ESD	LVA-100-14-AS-M8x43-ESD-C	100	M8	76	79	43	33	24	14	14	18000	91	146	
305453-ESD	LVA-100-14-M8x68-ESD-C	309453-ESD	LVA-100-14-AS-M8x68-ESD-C	100	M8	101	104	68	33	24	14	14	18000	103	158	
305461-ESD	LVA-100-14-M10x43-ESD-C	309461-ESD	LVA-100-14-AS-M10x43-ESD-C	100	M10	76	79	43	33	24	14	14	18000	100	155	
305463-ESD	LVA-100-14-M10x68-ESD-C	309463-ESD	LVA-100-14-AS-M10x68-ESD-C	100	M10	101	104	68	33	24	14	14	18000	112	167	
305465-ESD	LVA-100-14-M10x98-ESD-C	309465-ESD	LVA-100-14-AS-M10x98-ESD-C	100	M10	131	134	98	33	24	14	14	18000	126	181	
305471-ESD	LVA-100-14-M12x43-ESD-C	309471-ESD	LVA-100-14-AS-M12x43-ESD-C	100	M12	76	79	43	33	24	14	14	18000	110	165	
305473-ESD	LVA-100-14-M12x68-ESD-C	309473-ESD	LVA-100-14-AS-M12x68-ESD-C	100	M12	101	104	68	33	24	14	14	18000	127	182	
305475-ESD	LVA-100-14-M12x98-ESD-C	309475-ESD	LVA-100-14-AS-M12x98-ESD-C	100	M12	131	134	98	33	24	14	14	18000	148	203	
305477-ESD	LVA-100-14-M14x68-ESD-C	309477-ESD	LVA-100-14-AS-M14x68-ESD-C	100	M14	101	104	68	33	24	14	14	18000	149	204	
305479-ESD	LVA-100-14-M14x98-ESD-C	309479-ESD	LVA-100-14-AS-M14x98-ESD-C	100	M14	131	134	98	33	24	14	14	18000	170	225	
305480-ESD	LVA-100-14-M14x148-ESD-C	309480-ESD	LVA-100-14-AS-M14x148-ESD-C	100	M14	181	184	148	33	24	14	14	18000	253	308	
305481-ESD	LVA-100-14-M16x68-ESD-C	309481-ESD	LVA-100-14-AS-M16x68-ESD-C	100	M16	101	104	68	33	24	16	14	18000	171	226	
305483-ESD	LVA-100-14-M16x108-ESD-C	309483-ESD	LVA-100-14-AS-M16x108-ESD-C	100	M16	141	144	108	33	24	16	14	18000	223	278	
305485-ESD	LVA-100-14-M16x148-ESD-C	309485-ESD	LVA-100-14-AS-M16x148-ESD-C	100	M16	181	184	148	33	24	16	14	18000	275	330	
305487-ESD	LVA-100-14-M16x168-ESD-C	309487-ESD	LVA-100-14-AS-M16x168-ESD-C	100	M16	201	204	168	33	24	16	14	18000	301	356	
305521-ESD	LVA-100-24-M16x58-ESD-C	309521-ESD	LVA-100-24-AS-M16x58-ESD-C	100	M16	101	104	58	43	24	24	24	25000	251	305	
305525-ESD	LVA-100-24-M16x98-ESD-C	309525-ESD	LVA-100-24-AS-M16x98-ESD-C	100	M16	141	144	98	43	24	24	24	25000	302	356	
305541-ESD	LVA-100-24-M16x138-ESD-C	309541-ESD	LVA-100-24-AS-M16x138-ESD-C	100	M16	181	184	138	43	24	24	24	25000	352	406	
305561-ESD	LVA-100-24-M16x158-ESD-C	309561-ESD	LVA-100-24-AS-M16x158-ESD-C	100	M16	201	204	158	43	24	24	24	25000	379	433	
305625-ESD	LVA-100-24-M20x98-ESD-C	309625-ESD	LVA-100-24-AS-M20x98-ESD-C	100	M20	141	144	98	43	24	24	24	25000	372	426	
305641-ESD	LVA-100-24-M20x138-ESD-C	309641-ESD	LVA-100-24-AS-M20x138-ESD-C	100	M20	181	184	138	43	24	24	24	25000	451	505	
305661-ESD	LVA-100-24-M20x158-ESD-C	309661-ESD	LVA-100-24-AS-M20x158-ESD-C	100	M20	201	204	158	43	24	24	24	25000	490	544	
305681-ESD	LVA-100-24-M20x198-ESD-C	309681-ESD	LVA-100-24-AS-M20x198-ESD-C	100	M20	241	244	198	43	24	24	24	25000	573	627	
305725-ESD	LVA-100-24-M24x98-ESD-C	309725-ESD	LVA-100-24-AS-M24x98-ESD-C	100	M24	141	144	98	43	24	24	24	25000	470	524	
305761-ESD	LVA-100-24-M24x158-ESD-C	309761-ESD	LVA-100-24-AS-M24x158-ESD-C	100	M24	201	204	158	43	24	24	24	25000	642	696	
305781-ESD	LVA-100-24-M24x198-ESD-C	309781-ESD	LVA-100-24-AS-M24x198-ESD-C	100	M24	241	244	198	43	24	24	24	25000	760	814	
306521-ESD	LVA-125-24-M16x58-ESD-C	310221-ESD	LVA-125-24-AS-M16x58-ESD-C	125	M16	125	128	58	67	46	24	24	28000	386	512	
306525-ESD	LVA-125-24-M16x98-ESD-C	310225-ESD	LVA-125-24-AS-M16x98-ESD-C	125	M16	165	168	98	67	46	24	24	28000	437	563	
306541-ESD	LVA-125-24-M16x138-ESD-C	310241-ESD	LVA-125-24-AS-M16x138-ESD-C	125	M16	205	208	138	67	46	24	24	28000	487	613	
306561-ESD	LVA-125-24-M16x158-ESD-C	310261-ESD	LVA-125-24-AS-M16x158-ESD-C	125	M16	225	228	158	67	46	24	24	28000	514	640	
306625-ESD	LVA-125-24-M20x98-ESD-C	310325-ESD	LVA-125-24-AS-M20x98-ESD-C	125	M20	165	168	98	67	46	24	24	28000	507	633	
306641-ESD	LVA-125-24-M20x138-ESD-C	310341-ESD	LVA-125-24-AS-M20x138-ESD-C	125	M20	205	208	138	67	46	24	24	28000	586	712	
306661-ESD	LVA-125-24-M20x158-ESD-C	310361-ESD	LVA-125-24-AS-M20x158-ESD-C	125	M20	225	228	158	67	46	24	24	28000	625	751	
306681-ESD	LVA-125-24-M20x198-ESD-C	310381-ESD	LVA-125-24-AS-M20x198-ESD-C	125	M20	265	268	198	67	46	24	24	28000	708	834	
306725-ESD	LVA-125-24-M24x98-ESD-C	310425-ESD	LVA-125-24-AS-M24x98-ESD-C	125	M24	165	168	98	67	46	24	24	28000	605	731	
306761-ESD	LVA-125-24-M24x158-ESD-C	310461-ESD	LVA-125-24-AS-M24x158-ESD-C	125	M24	225	228	158	67	46	24	24	28000	777	903	
306781-ESD	LVA-125-24-M24x198-ESD-C	310481-ESD	LVA-125-24-AS-M24x198-ESD-C	125	M24	265	268	198	67	46	24	24	28000	895	1021	

* The max static load is the value above which the load applied to the element may cause some plastic material breakage, in particular conditions of use. Obviously, a factor that takes into consideration the importance and the safety level of the specific application must be applied to this value.

Data with no-slip disk mounted.